

Engine bay and transmission elements skid plate has been designed and manufactured by LLC Metalloproduksia. Product conforms to TOR 4591-001-25888788-2006 requirements. Product design is protected by model copyright certificates №89059, 15980, 15981, 15982, 15983. Patented in Russian Federation.

APPLICATION:

Protection of engine bay and transmission elements from mechanical deformation.
Protection of engine bay and transmission elements from dust and damp.

INSTALLATION:

Engine bay and transmission elements skid plate has been designed particularly for a certain vehicle. It should be mounted according to the producer's installation instruction by a dedicated dealer or on certified service stations. The skid plate is fixed to regular apertures located on vehicle's body load-bearing elements. In case of correct installation the skid plate should not interfere with any vehicle's units and components.

INSTALLATION MANUAL:

1. Install the skid plate for transmission case only after the skid plate for engine bay has been mounted.
2. Fix the front skid plate's element over the skid plate for engine bay with bolts M 8x20 and threaded insert "3" -(B).
3. Fix the rear part of the skid plate to the crossbar apertures with bolts M 8x20 -(A).
4. Mount rear element over the front element and fix it to the car's load bearing element with bolt M 10x20 and threaded insert "2" -(C).
5. Tighten all screw joints

OPERATING CONDITIONS:

Engine bay and transmission elements skid plate has been designed to operate in conditions specified by vehicle's producer. Cases of crush or driving into obstacles at a speed should be excluded during exploitation. In case of head-on crush it is necessary to assure in absence of damages of vehicle's components and units and availability of roadworthiness on certified service stations.

WARRANTY:

Warranty period - 24 months.

WARRANTY TERMS:

The skid plate should be installed on a vehicle with undamaged body and load-bearing elements (vehicle, which has never been involved in road traffic accident);

There are no mechanical damages of the skid plate resulting from head-on crush. All requirements to skid plate installation should be satisfied;

There are no mechanical damages of powder coating.

Producer does not bear liability for damages caused to the vehicle, health and life of people in case of installation and exploitation terms violation. Producer has a right to introduce changes into the skid plate construction.



The Quality Management System of LLC Metalloproduksia has been audited by Bureau Veritas Certification and conforms to requirements of the ISO 9001:2008 standard.

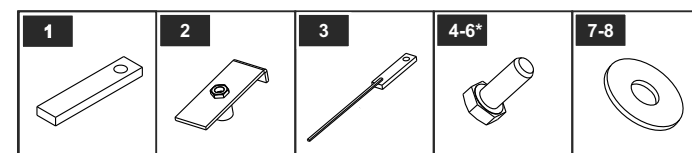
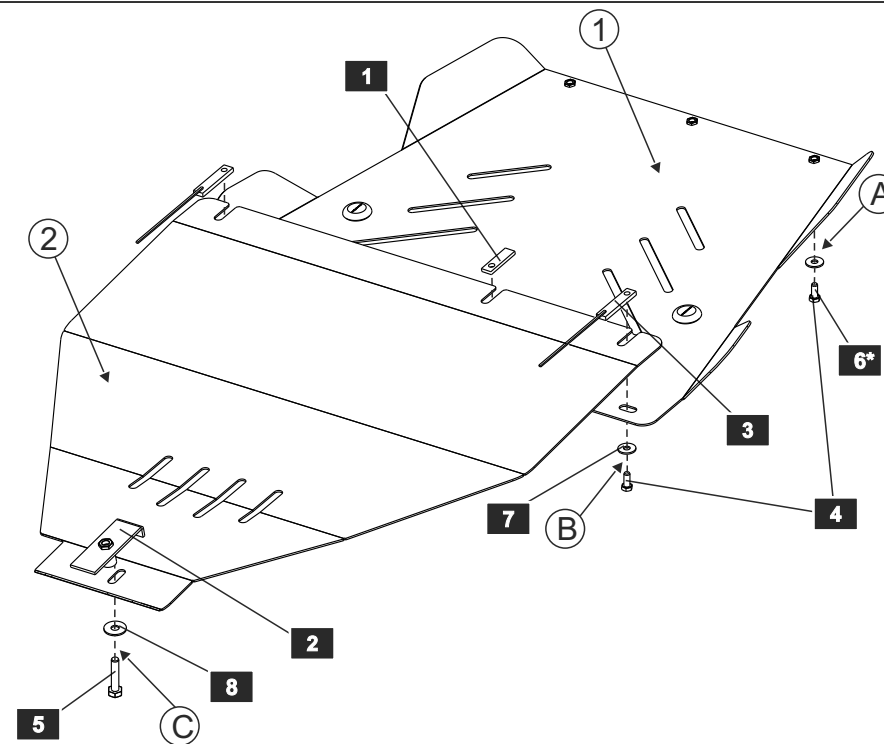

LIST OF PARTS

NO.	NAME	QTY.	NO.	NAME	QTY.
1	Threaded insert	1	5	Bolt M 10x50	1
2	Threaded insert	1	6*	Bolt M 10x20*	3*
3	Threaded insert with tail	2	7	Washer 8	6(3*)
4	Bolt M 8x20 (M8x30*)	6 (3*)	8	Washer 10	1(4*)

*- For 1697(Aluminium)

Thread	M6x1.0	M8x1.25	M10x1.5	M12x1.75
Tightening torque	9.8 Nm	24.0 Nm	47.0 Nm	81.0 Nm