

# Towbar

## 6065



Audi; Skoda; Seat; VW

- A3 2012->
- A3 Limousine 2014->
- A3 Sportback 2012->
- A3 Cabrio 2014->
- A3 Cabrio S-line 2014->
- Octavia 2013->
- Octavia Combi 2013->
- Octavia RS 2013->
- Octavia RS Combi 2013->
- Leon 2013->
- Leon SC 2013->
- Leon FR 2013->
- Leon SC FR 2013->
- Leon SC FR Edition 2013->
- Leon ST 2013->
- Leon ST FR 2013->
- Golf 2012->
- Golf GTI 2013->
- Golf Sportsvan 2014->

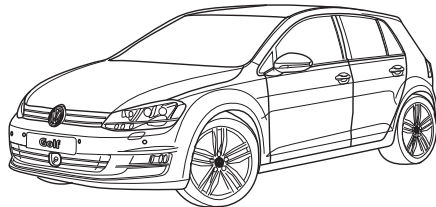
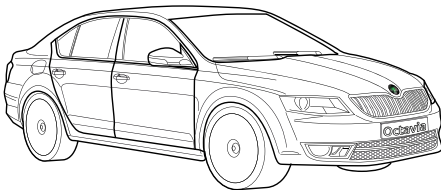
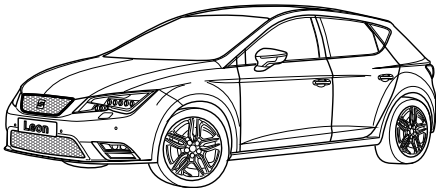
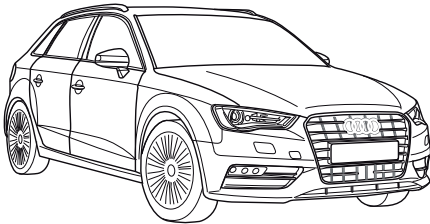

- NL Montagehandleiding
- GB Fitting instructions
- D Montageanleitung
- F Instructions de montage
- S Monteringsanvisningar
- DK Montagevejledning
- E Instrucciones de montaje
- I Istruzioni per il montaggio
- PL Instrukcja montażu
- SF Asennusohjeet
- CZ Pokyny k montáži
- H Szerelési útmutató
- RUS Руководство для монтажа

**BRiNK**<sup>®</sup>





**Your perfect fit**  
brink.eu

**(B)** Audi A3 Limouine S-line  
 Audi A3 Sportback  
 Audi A3 Cabrio S-line  
 Škoda Octavia RS  
 Škoda Octavia Combi  
 Škoda Octavia Combi RS

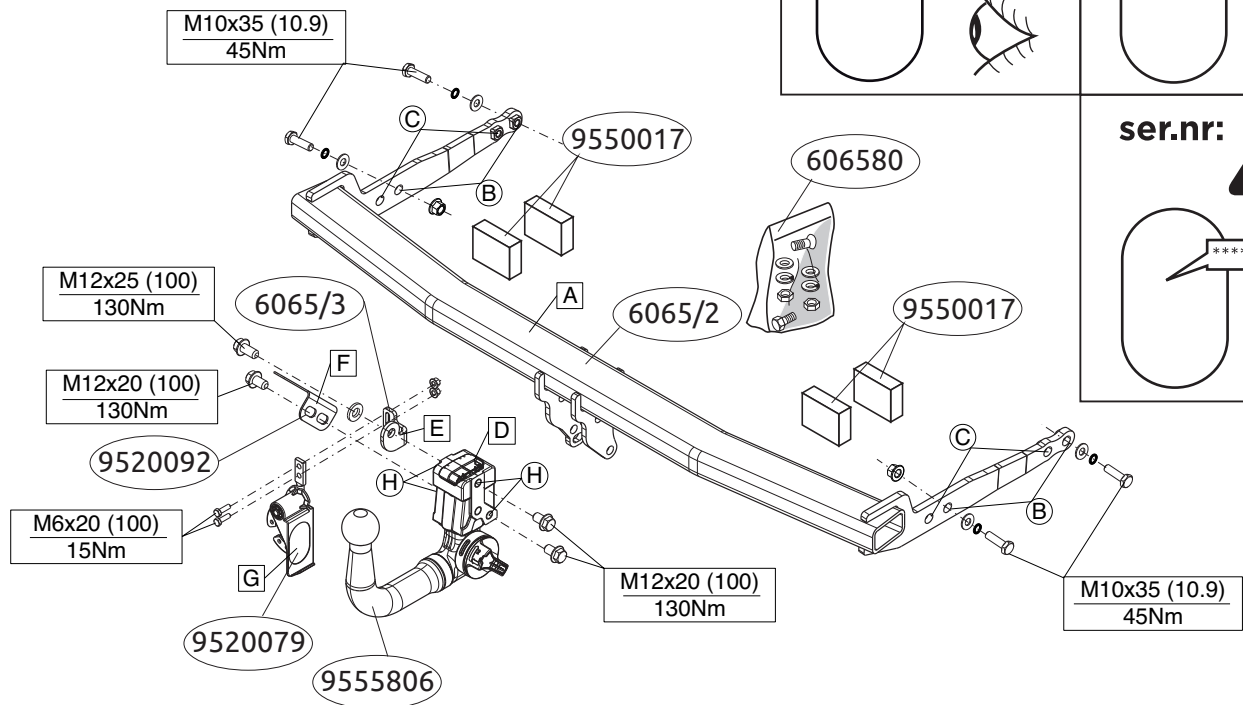
**(C)** Audi A3  
 Audi A3 Limousine  
 Audi A3 Cabrio  
 Seat Leon  
 Seat Leon SC  
 Seat Leon SC FR  
 Seat Leon SC FR Edition  
 Seat Leon ST

Seat Leon ST FR  
 VW Golf  
 VW Golf GTI  
 VW Golf Sportsvan

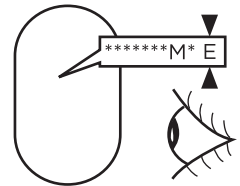

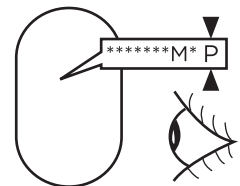
|  |   |
|--|---|
| <p><b>ser.nr:</b> </p>  | <p><b>ser.nr:</b> </p>  |
|  | <p><b>ser.nr:</b> </p>  |

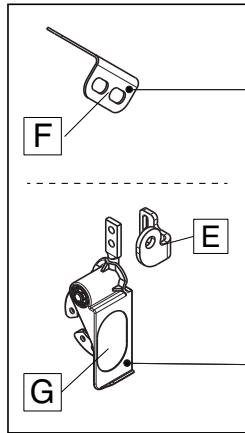

Socketplate

Foldway  
socketplate

Audi A3 Sportback  
Audi A3 Cabrio S-line  
Audi A3  
Audi A3 Limousine  
Audi A3 Cabrio

G

Škoda Octavia  
Škoda Octavia RS  
Škoda Octavia Combi  
Škoda Octavia Combi RS

G

Seat Leon  
Seat Leon FR  
Seat Leon SC  
Seat Leon ST FR  
Seat Leon SC FR Edition

F

Seat Leon ST

G

VW Golf  
VW Golf GTI  
VW Golf Sportsvan

G

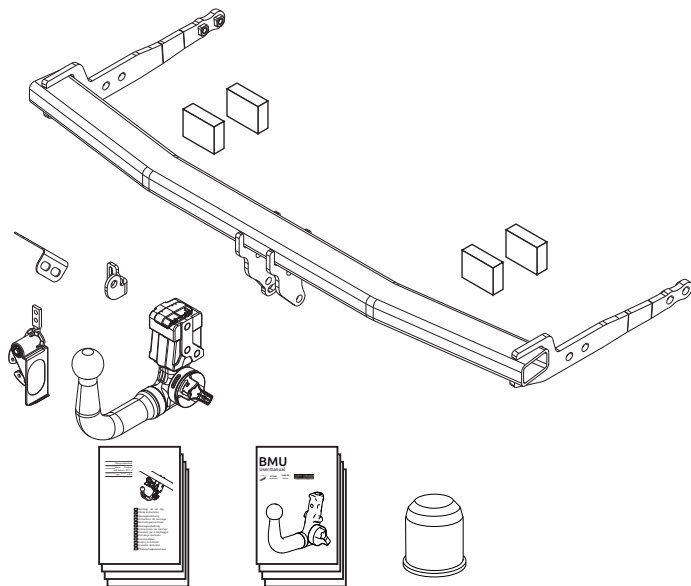
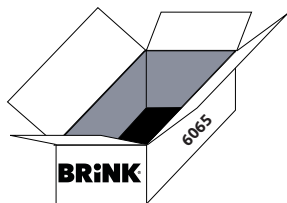

(3x) M12x20 (100)



(1x) M12x25 (100)



(4x) M10x35 (10.9)



(2x) M6x20 (10.9)



(2x) M6



(4x) M10



(4x) M10



(1x) M12

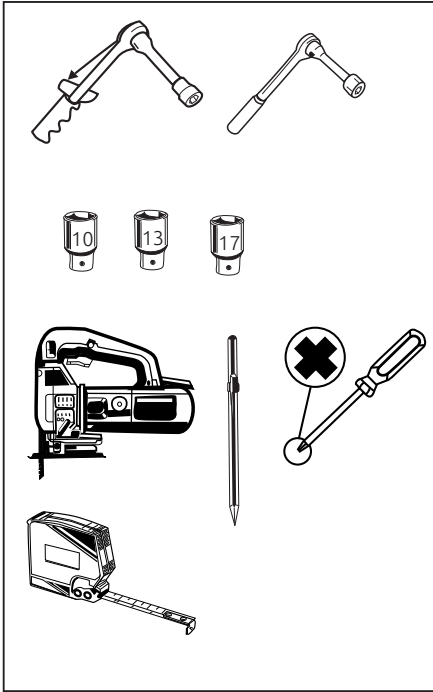

Couplingsclass: A50-X

euro tested

Approved

E11 55R 0110810

ECE R55

**D-Value : 10,3 kN**

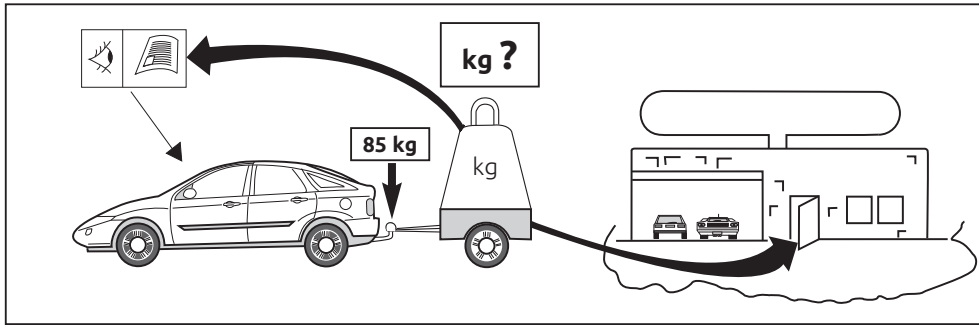

8.8

10.9

10

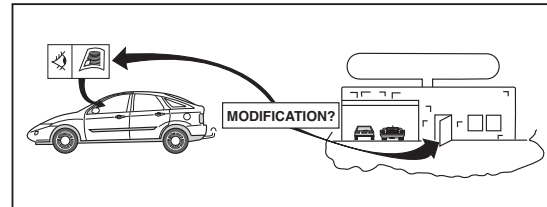

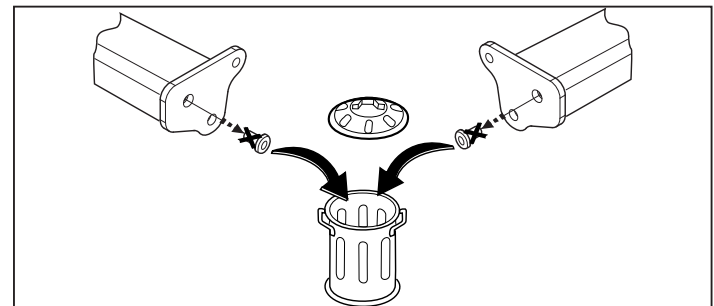
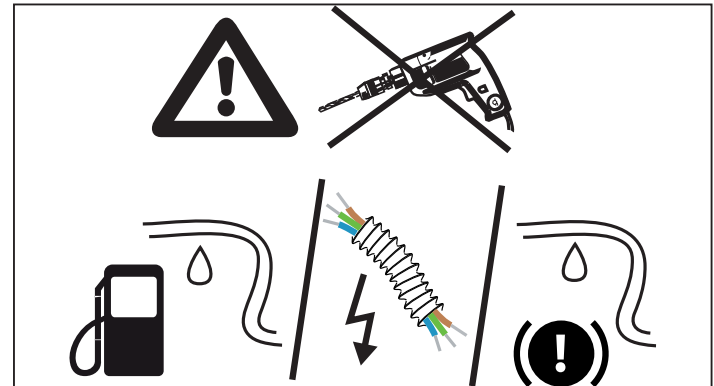
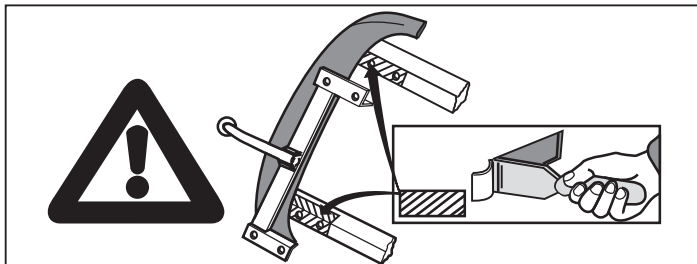
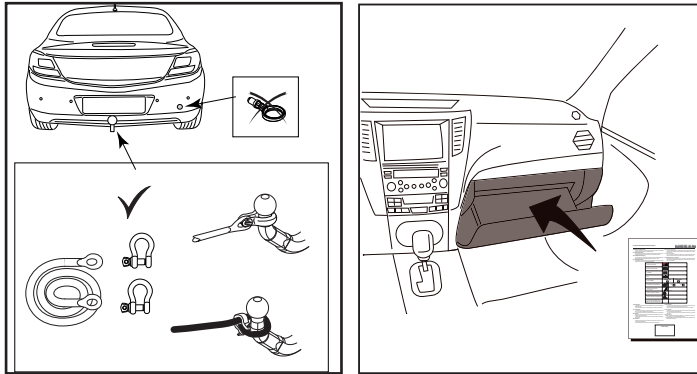
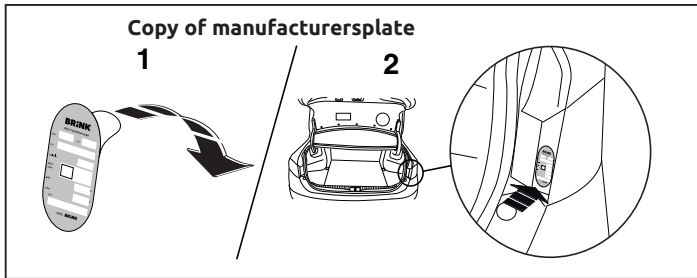

NL

\* Brink Towing Systems B.V. is niet aansprakelijk voor de schade die het direct of indirect gevolg is van onjuiste montage, daaronder begrepen gebruik van niet-geschikte gereedschappen en het gebruik van andere dan de voorgeschreven montagewijze en middelen, dan wel onjuiste interpretatie van dit onderhavig montagevoorschrift.

GB

**NOTE:**

\* **Should this installation process entail the cutting of the bumper – conformation MUST be obtained by the installation engineer of the customer's acceptance prior to completion. Brink Towing Systems B.V. do not accept responsibility for any matters arising as a result of this miscommunication.**

**All measurements are in mm!**

\* Brink Towing Systems B.V. is not liable for damage caused directly or indirectly by incorrect assembly, including the use of unsuitable tools, the use of other assembly methods and means than the ones outlined, and the incorrect interpretation of these assembly instructions.

D

**HINWEISE:**

\* Die für das Fahrzeug zugelassene Anhängelast ist den Fahrzeug Unterlagen zu entnehmen. Bei Änderungen des Fahrzeuggewichtes muß die höchstzulässige Anhängelast gegebenenfalls aus dem D-Wert nachgerechnet werden. Auskunft hierüber kann Ihr Fachhändler oder der TÜV geben.

\* Elektrische Anlage gemäß StVZO anbringen.

\* Brink Towing Systems B.V. haftet nicht für Schäden, die als direkte oder indirekte Folge einer nicht ordnungsgemäßen Montage auftreten, darunter fallen auch die Benutzung von ungeeigneten Werkzeugen, andere als die vorgeschriebenen Montageverfahren und Montagemittel

sowie eine fehlerhafte Interpretation der betreffenden Montageanweisung.

F

\* Brink Towing Systems B.V. décline toute responsabilité pour les dommages qui pourraient directement ou indirectement résulter d'un montage incorrect, y compris l'utilisation d'outils inappropriés et l'utilisation d'un mode d'emploi et de moyens autres que ceux prescrits, ou bien résulter d'une interprétation inexacte des présentes instructions de montage.

S

\* Brink Towing Systems B.V. är inte ansvariga för skada som orsakats direkt eller indirekt av felaktig montering, inklusive användning av olämpliga verktyg, andra monteringsmetoder och processer än de som beskrivs, samt felaktig tolkning av dessa monteringsinstruktioner.

DK

\* Brink Towing Systems B.V. er ikke ansvarlig for skade der direkte eller indirekte er forårsaget af forkert montage, herunder også iberegnet brug af forkert værktøj og anvendelse af anden montage metode og andre montage midler end de foreskrevne samt fejltolkning af den medfølgende montagevejledning.

E

\* Brink Towing Systems B.V. no se responsabiliza por daños causados, directa o indirectamente, por un montaje incorrecto, incluyendo el uso de herramientas inadecuadas, por el uso de métodos de montaje y medios distintos a los indicados y por la interpretación incorrecta de estas instrucciones de montaje.

I

\* Brink Towing Systems B.V. non può essere ritenuta responsabile per eventuali danni direttamente o indirettamente dovuti ad un errato montaggio, intendendo con ciò anche l'uso di attrezzi non idonei e l'uso di metodi e mezzi di montaggio diversi da quelli prescritti, nonché all'errata interpretazione delle seguenti istruzioni di montaggio.

PL

\* Brink Towing Systems B.V. nie ponosi odpowiedzialności za straty poniesione pośrednio lub bezpośrednio na skutek niewłaściwego montażu, w tym użycia niewłaściwych narzędzi i sposobów montażu niezgodnych z instrukcją, oraz niezastosowanie się do treści instrukcji.

SF

\* Brink Towing Systems B.V. ei ole vastuussa vioittumisesta, joka on suoraan tai epäsuoraan aiheutunut väärästä asennuksesta samoin kuin sopimattomien työkalujen käytöstä, muiden kuin ohjeissa mainittujen asennusmenetelmien tai välineiden käytöstä sekä kyseisten asennusohjeiden väärintulkinnasta.

CZ

\* Společnost Brink Towing Systems B.V. neodpovídá za přímé ani nepřímé škody způsobené nesprávnou montáží, včetně použití nevhodných nástrojů, použití jiných metod montáže a prostředků než uvedených a nesprávným pochopením těchto pokynů k montáži.

H

\* A Brink Towing Systems B.V. nem vállal felelősséget a nem megfelelő szerelésből közvetlen vagy közvetett módon következő károkért. Ez vonatkozik a nem megfelelő szerszámok használatára, a leírtaktól eltérő módszerek és eszközök alkalmazására, valamint a szerelési útmutató

téves értelmezésére.

RUS

\* Фирма Brink Towing Systems B.V. не отвечает за ущерб, являющийся прямым или косвенным следствием неправильного монтажа, в том числе использования неподходящих инструментов и применения иного способа монтажа или других средств, чем предписано в инструкции, либо неправильного истолкования настоящей инструкции по монтажу.



# Audi

- NL** Lokatie/Positie pijl
- GB** Location/Position Arrow
- D** Positionspfeil
- F** Flèche de Position
- S** Positionpil
- DK** Lokaliseringspil
- E** Flecha de posición
- I** Freccia di posizione
- PL** Strzałka położenia
- SF** Paikannusnuoli
- CZ** Šípka na pozici
- H** Helyzetjelző nyíl
- RUS** Локация / Место встречи

- NL** Richtingspijl
- GB** Movement Arrow
- D** Bewegungspfeil
- F** Flèche de mouvement
- S** Rörelsepil
- DK** Bevægelsespil
- E** Flecha de movimiento
- I** Freccia di movimento
- PL** Strzałka kierunku ruchu
- SF** Liikesuuntanuoli
- CZ** Šípka pohybu
- H** Mozgásirányjelzőnyíl
- RUS** Стрелка движения

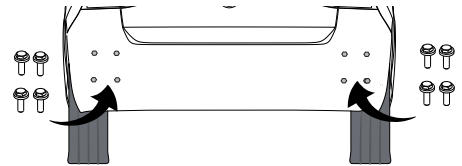
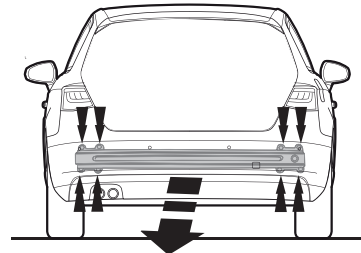
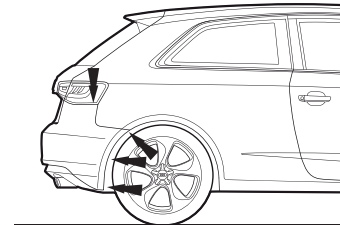
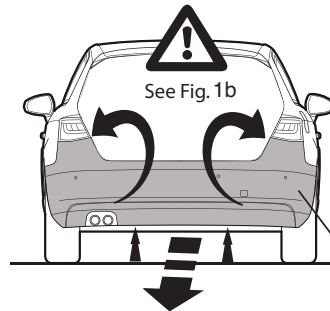
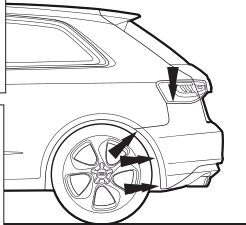
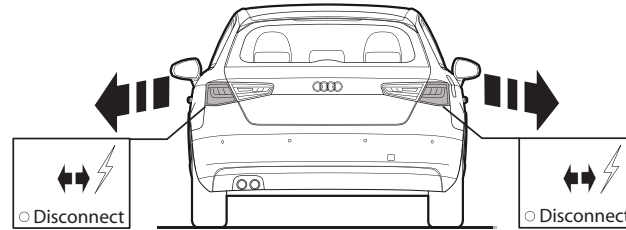

1a

**1**

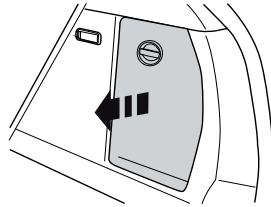
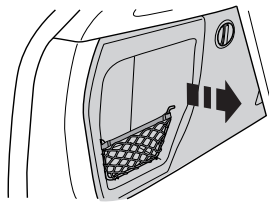

**2**

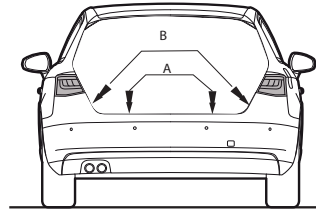
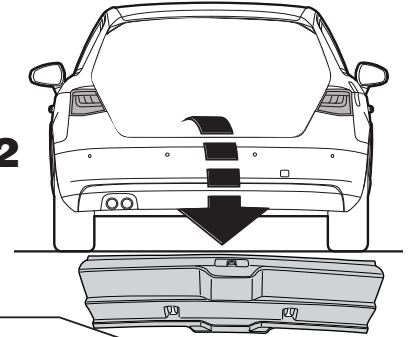

Audi

**3**

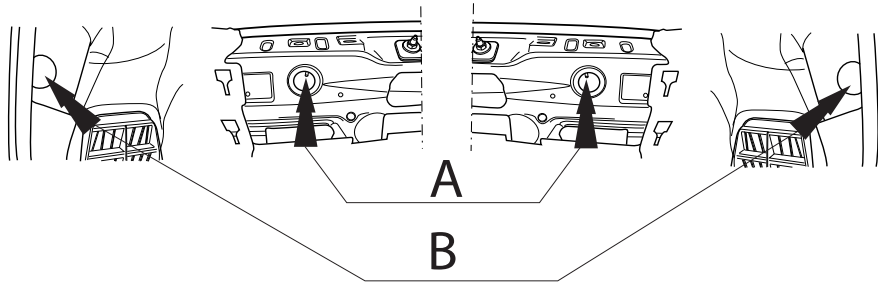

**1b**

Inside trunk / back panel

Skoda

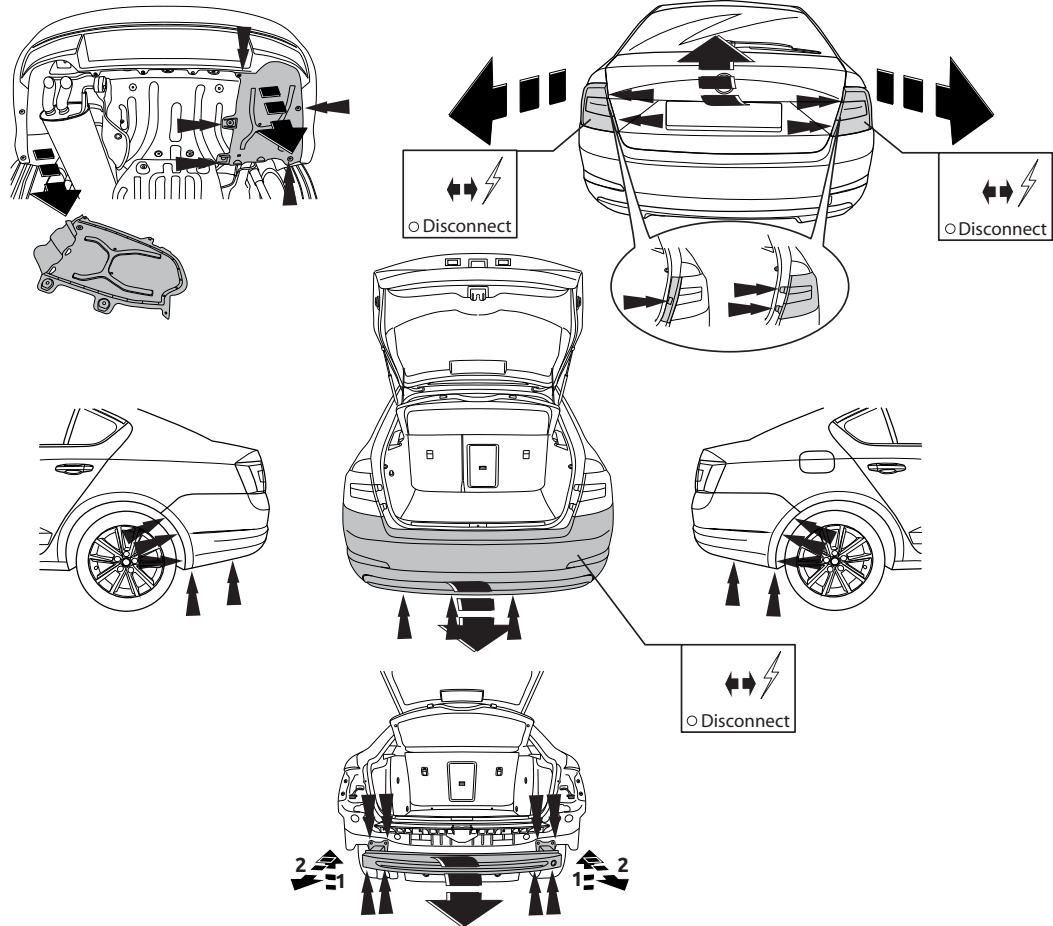

1c

# Seat

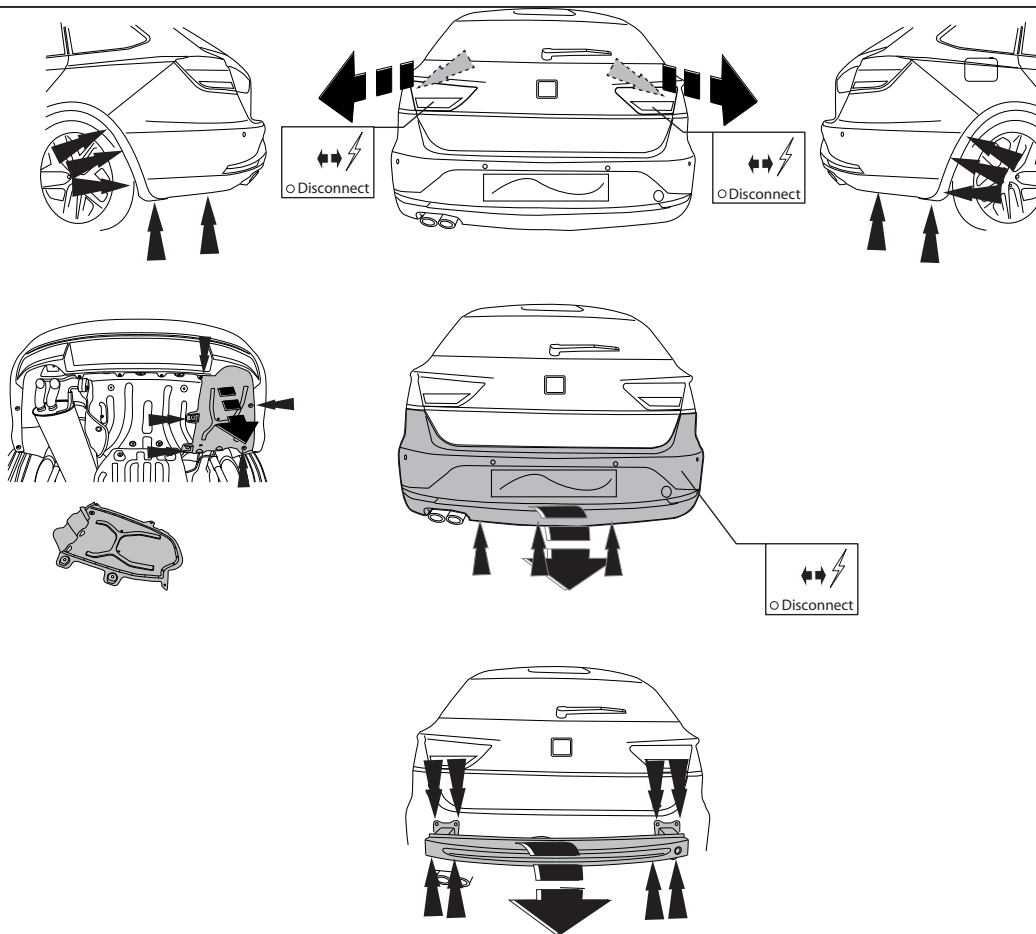

1d

# Volkswagen

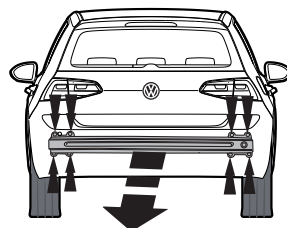
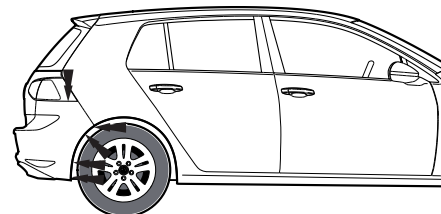
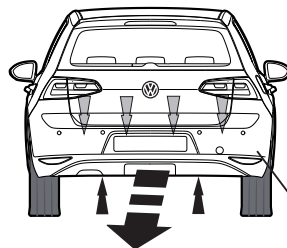
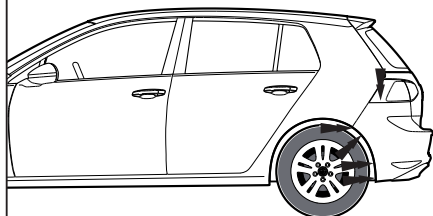
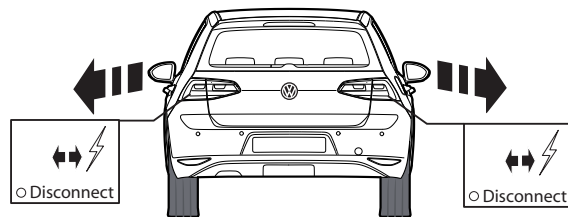

1e

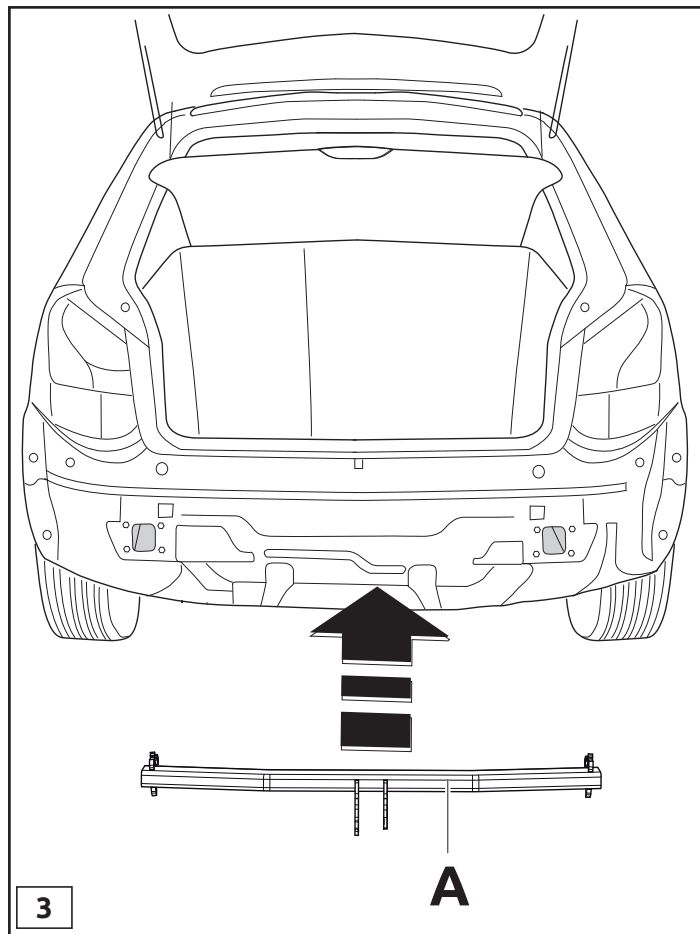
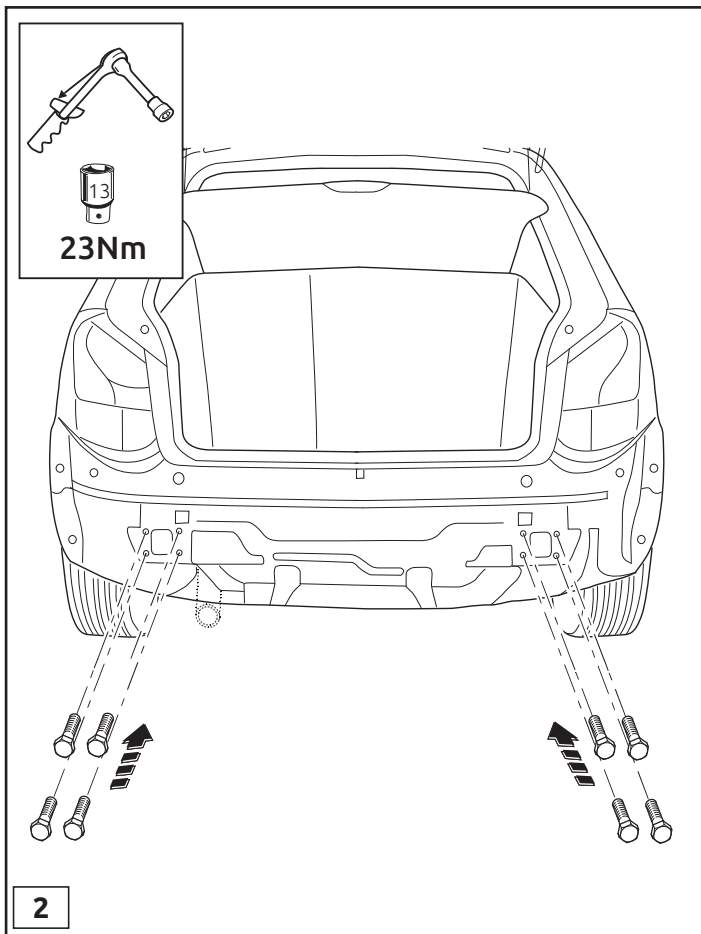

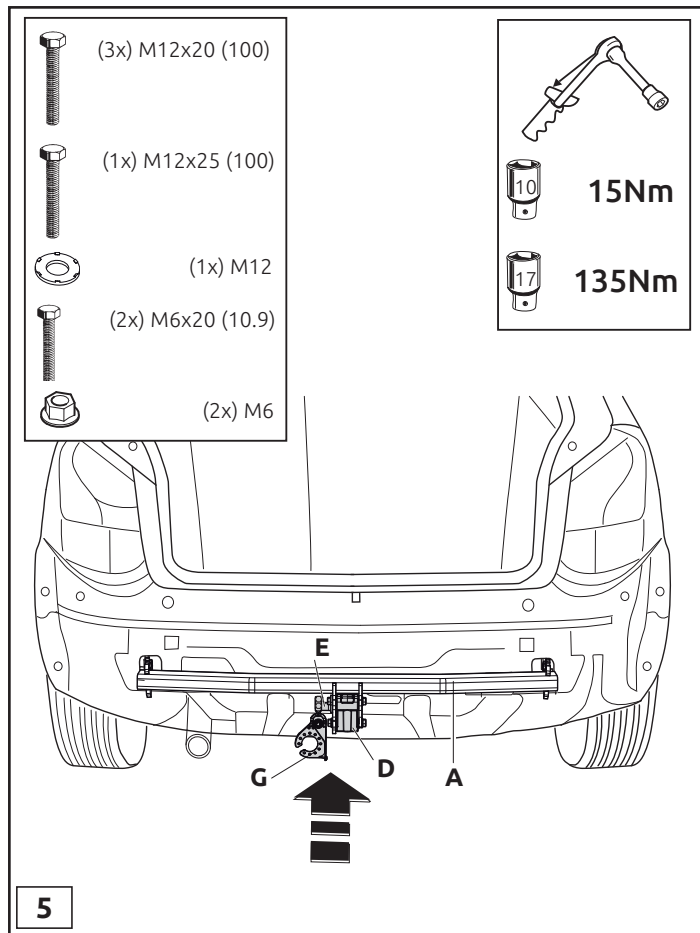
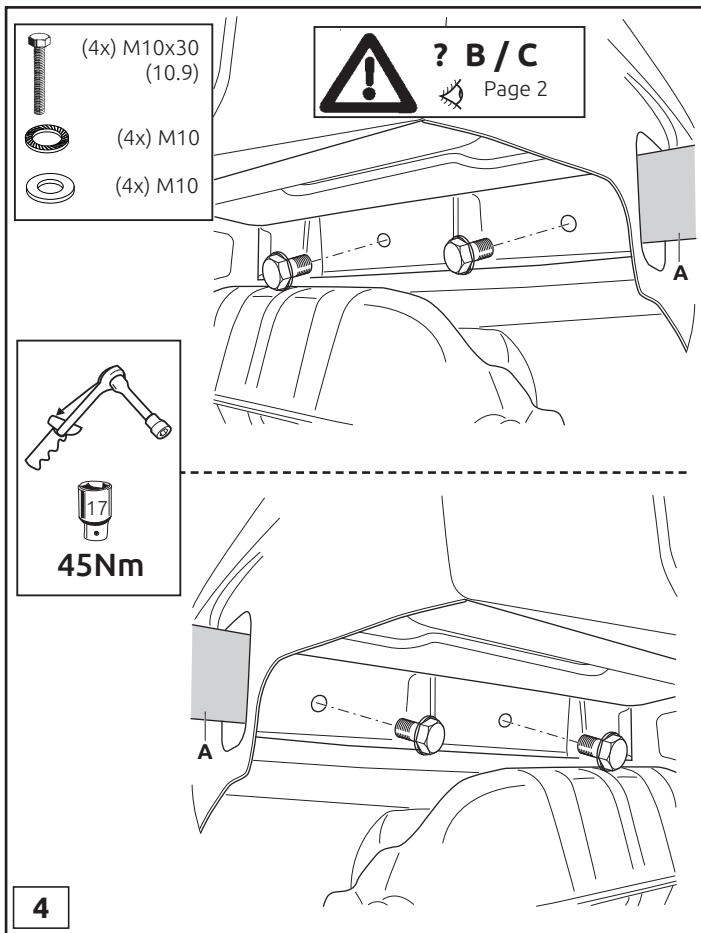

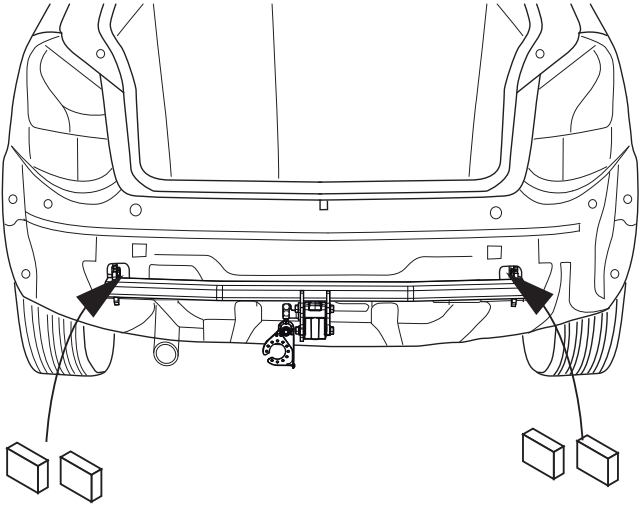
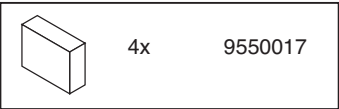

 Foldway socketplate

Audi A3  
Audi A3 Sportback

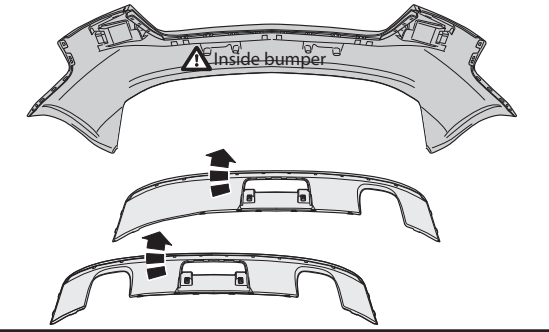
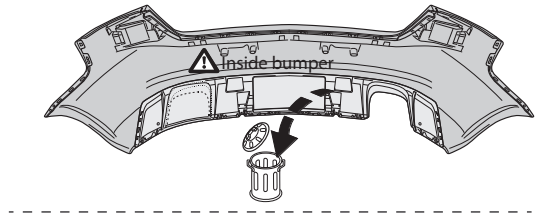
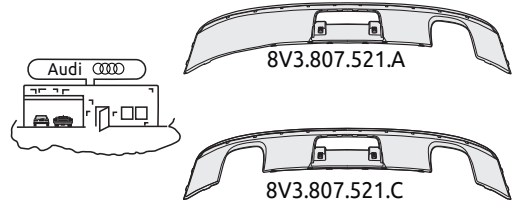

7





Foldway socketplate

Audi A3 Limousine

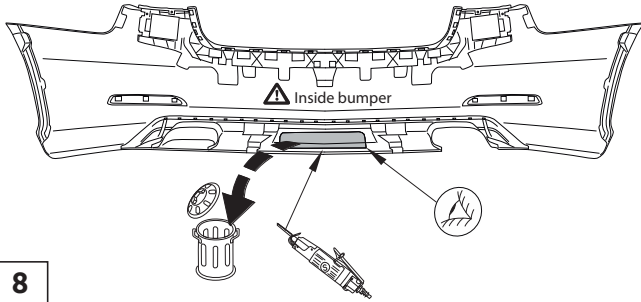

Foldway socketplate

Audi A3 Limousine

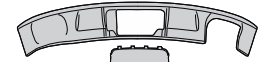
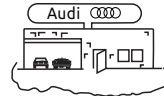

8V3.807.521.A

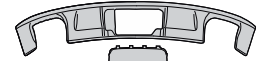

8V3.807.521.C

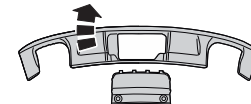
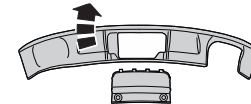
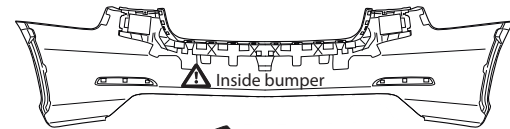
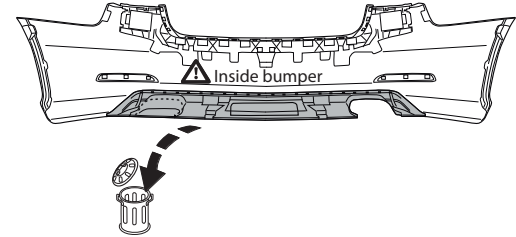

8a

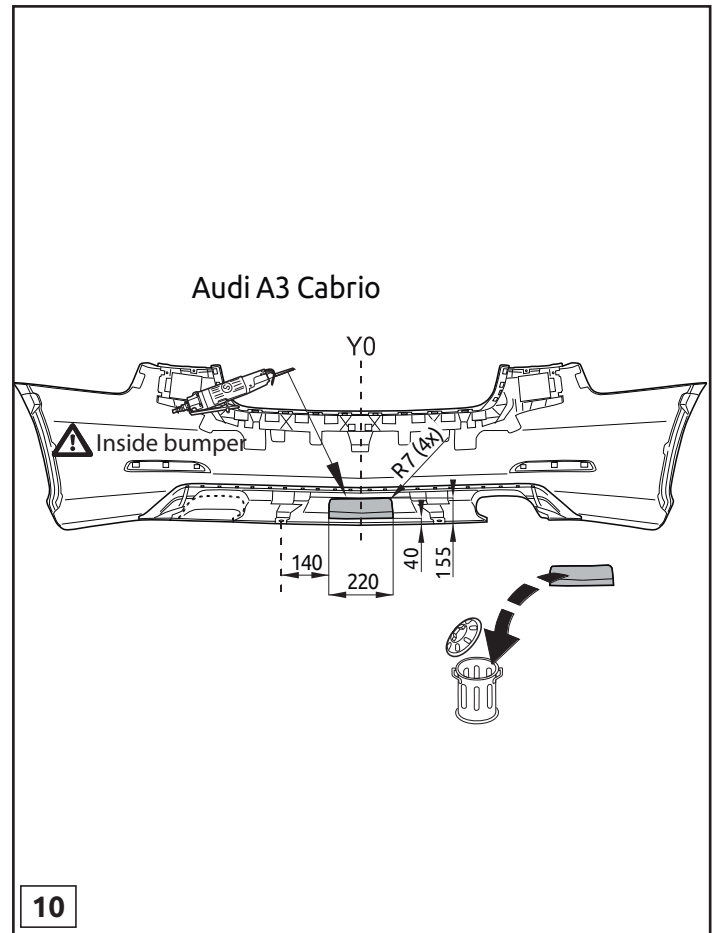
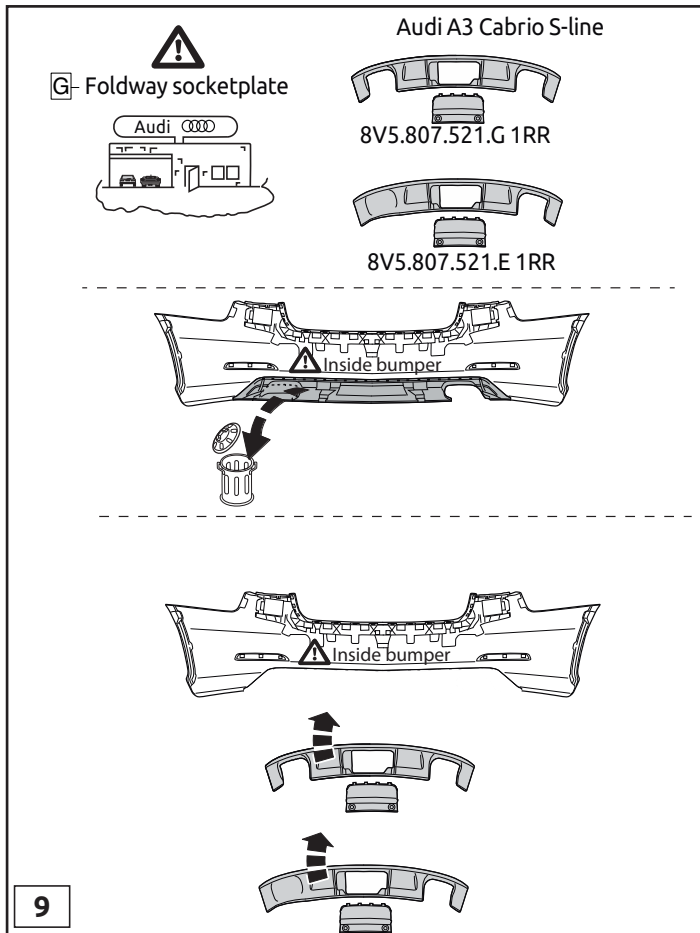

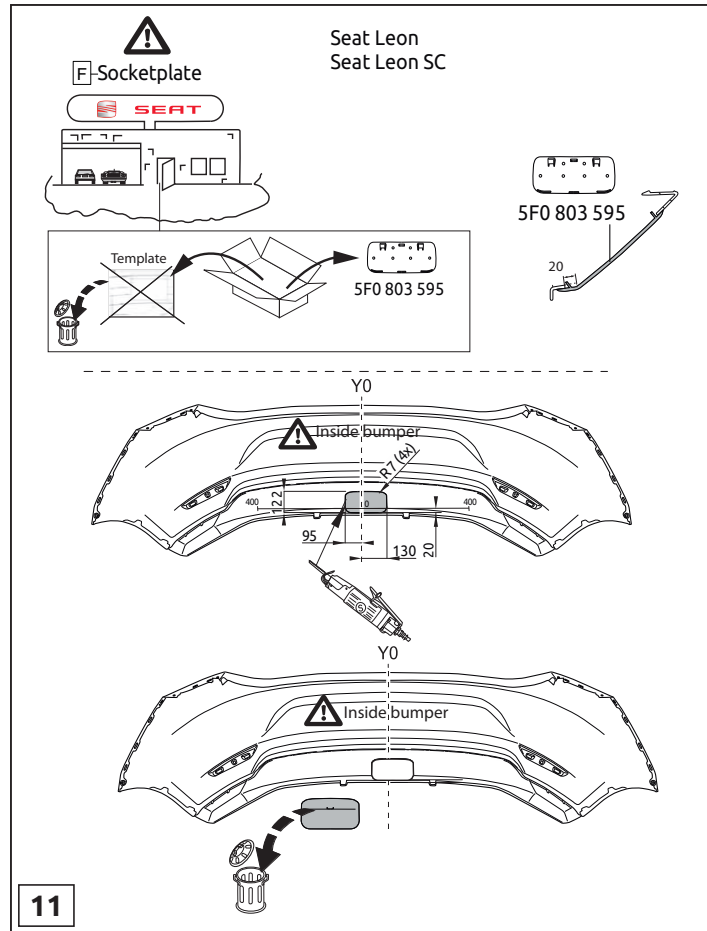
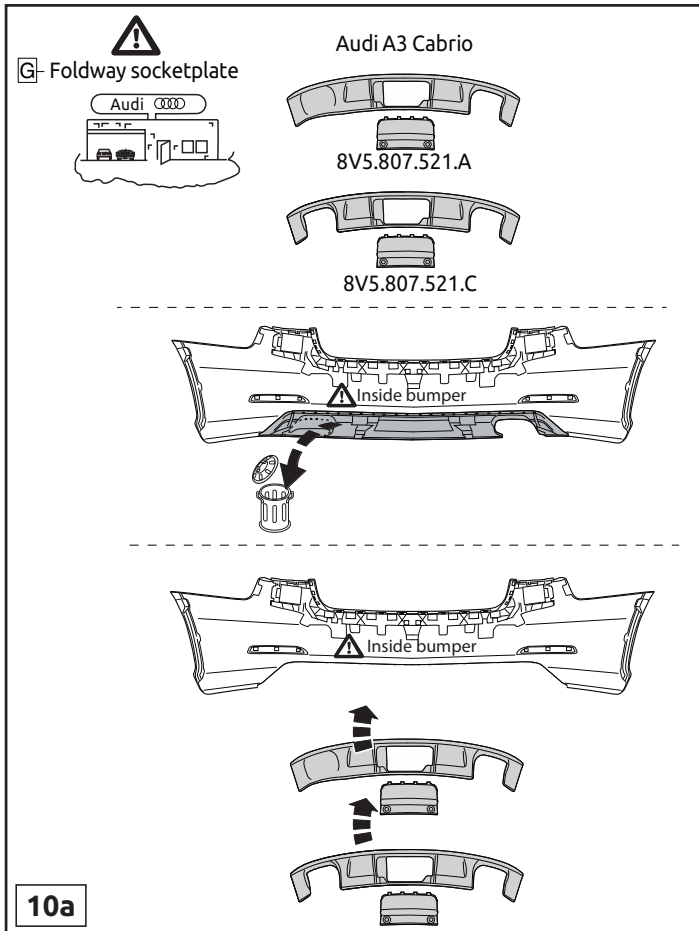

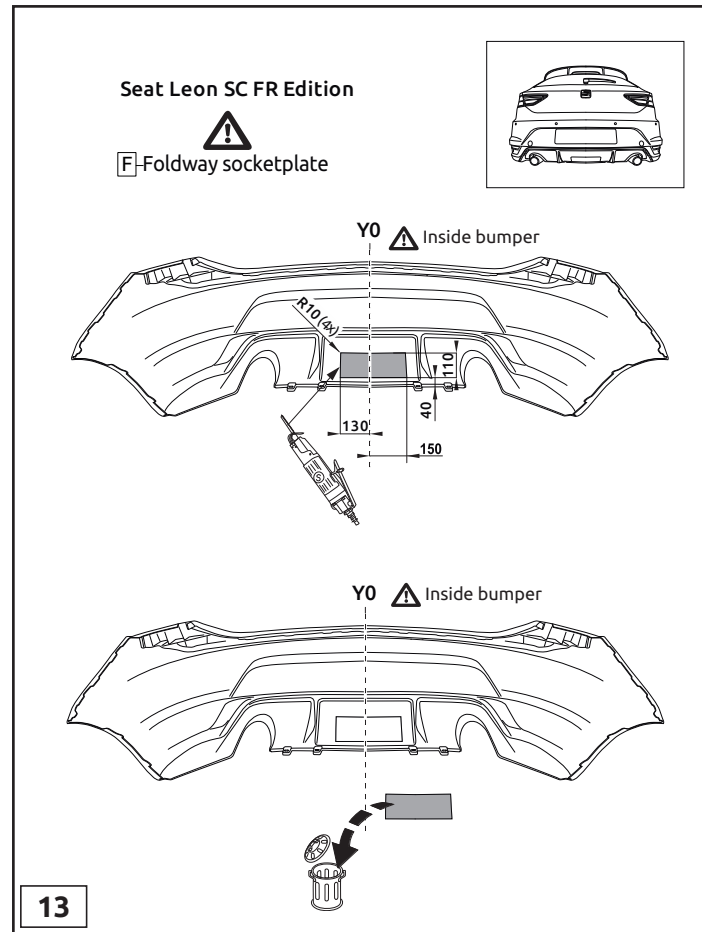
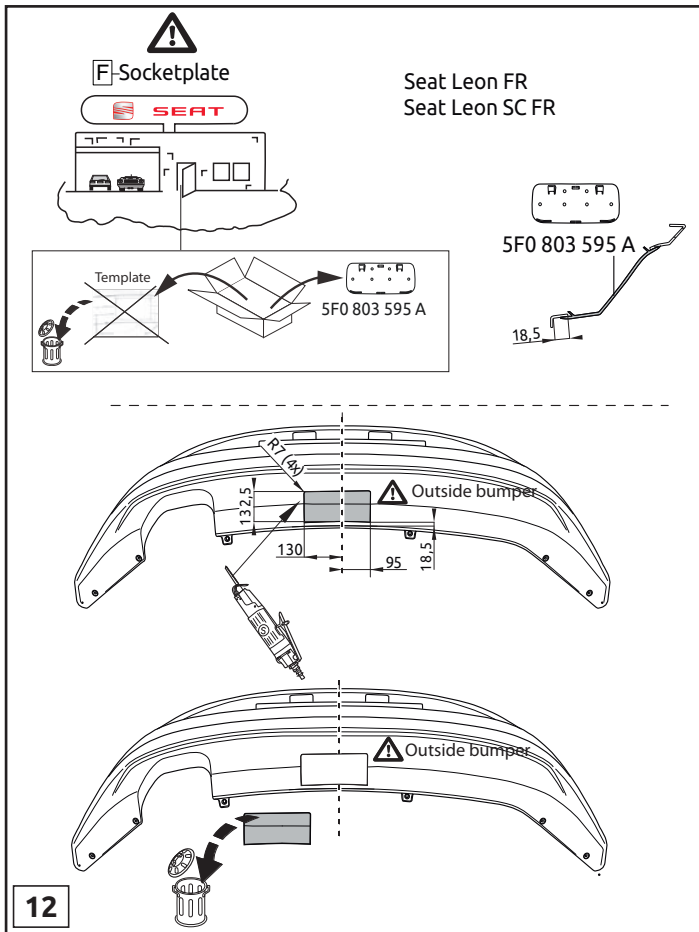

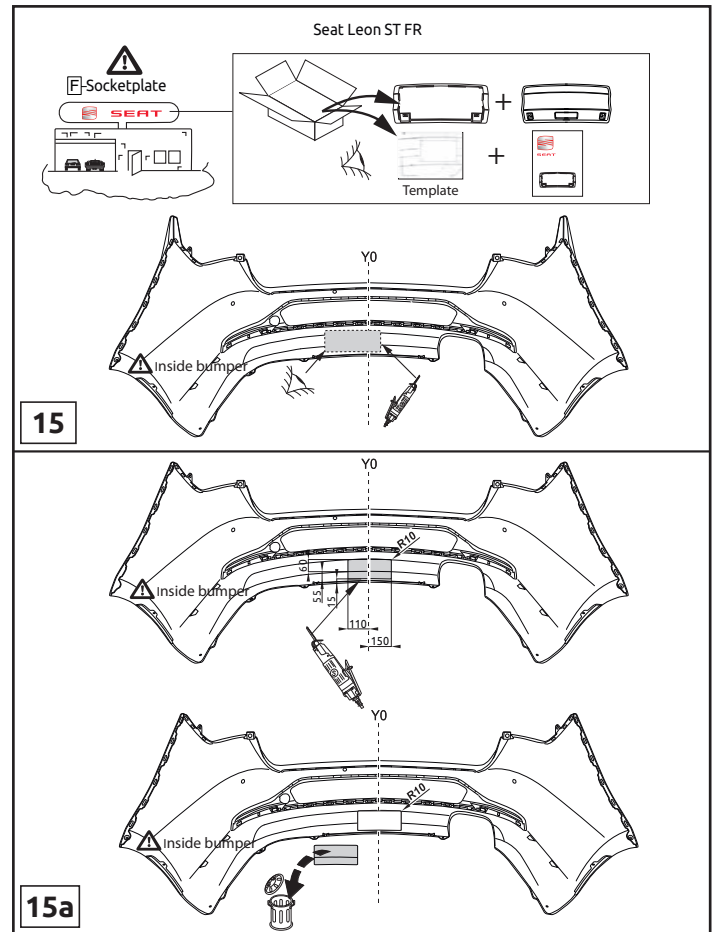
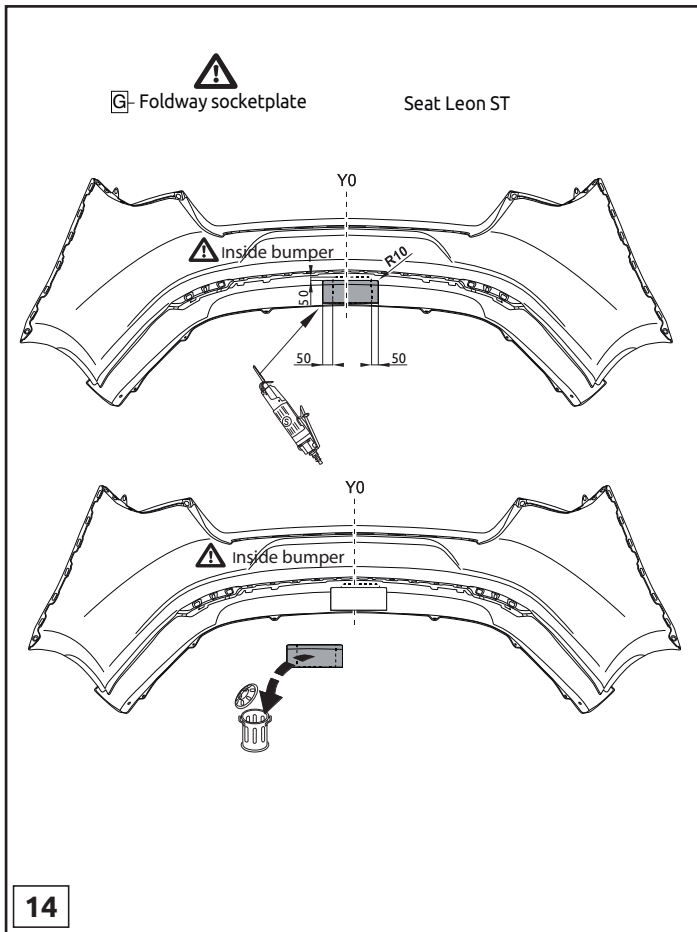

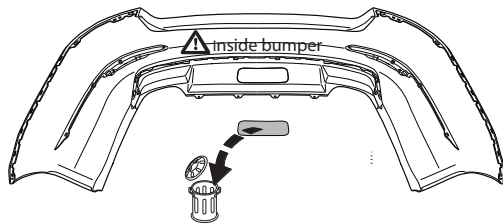
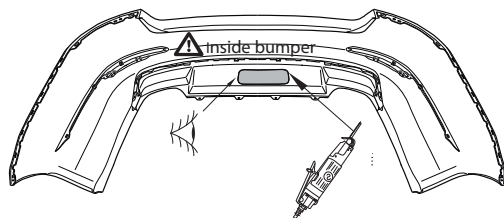

Škoda Octavia  
 Škoda Octavia Combi  
 Škoda Octavia RS  
 Škoda Octavia Combi RS

 Foldway socketplate



16

 Foldway socketplate

VW Golf

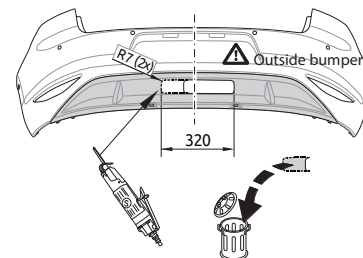
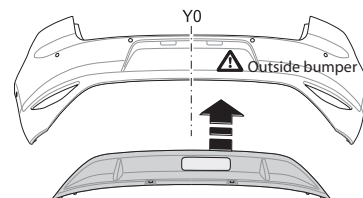
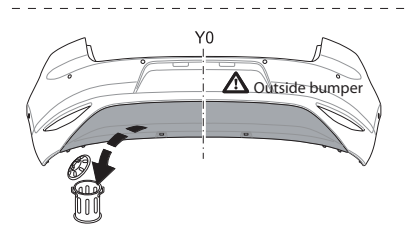
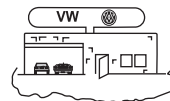

17

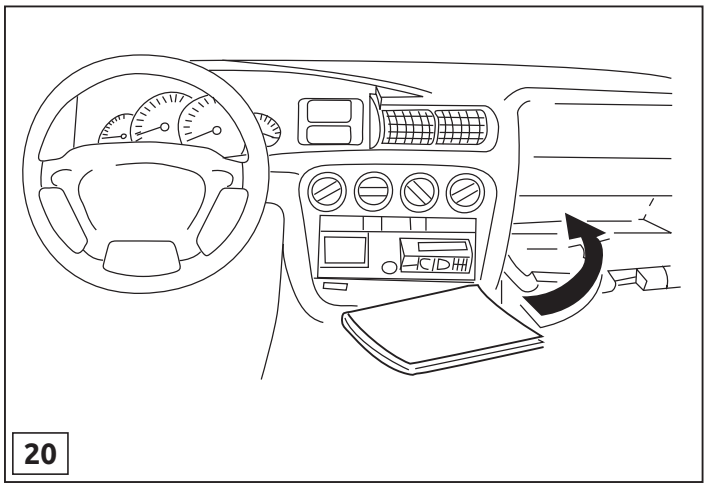
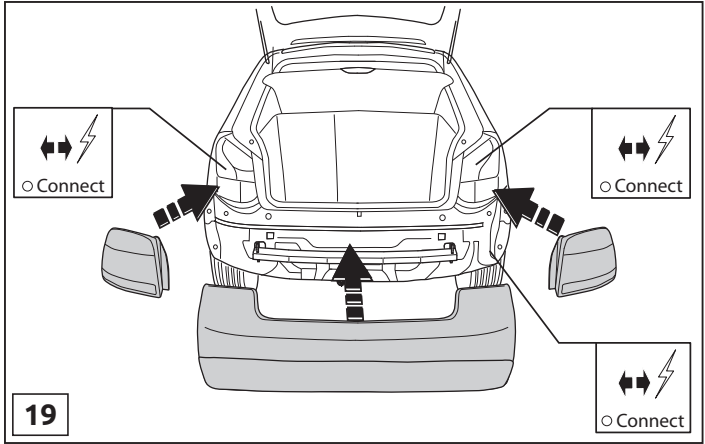
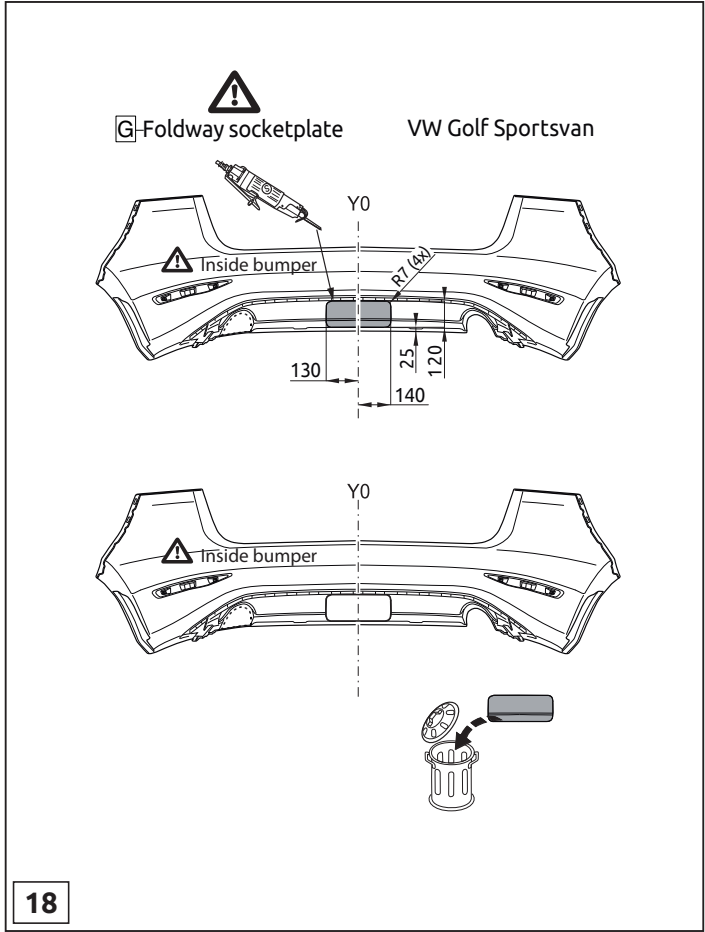











Dispositivo di traino tipo: 6065  
Per autoveicoli: Audi **A3** 2012->; **A3 Limousine** 2014->; **A3 Sportback** 2012->; **A3 Cabrio** 2014->; **A3 Cabrio S-line** 2014->  
Skoda **Octavia** 2013->; **Octavia Combi** 2013->; **Octavia RS** 2013->; **Octavia RS Combi** 2013->  
Seat **Leon** 2013->; **Leon SC** 2013->; **Leon FR** 2013->; **Leon SC FR** 2013->; **Leon SC FR Edition** 2013->; **Leon ST** 2013->;  
**Leon ST FR** 2013->  
Volkswagen **Golf** 2012->; **Golf GTI** 2013->; **Golf Sportsvan** 2014->  
Tipo funzionale: 5G, 8V, 5E, AU, 5F  
Classe e tipo di attacco: A50-X  
Omologazione: E11 55R 0110810  
Valore D: 10,3 kN  
Carico Verticale max. S: 85 kg  
Larghezza rimorchiabile per Caravan e T.A.T.S.: 2,45m vedere CARTA di CIRCOLAZIONE VEICOLO (motrice) + 70 cm = ..arrotondare ai 5 cm superiore (vedi D.M.28/05/85)  
Massa rimorchiabile: vedi carta di circolazione dell' autoveicolo

**Per verificare l'idoneità del dispositivo di traino omologato a norma UN ECE R55, all'installazione sulla vettura su cui si intende procedere al montaggio, compilare la seguente formula (se necessario declassare la massa rimorchiabile):**

$$D = \frac{T \times C}{T + C} \times 0,00981 \leq 10,3 \text{ kN}$$

dove: T= Massa Complessiva Max. della motrice (in kg)

C= Massa Rimorchiabile Max. della motrice (in kg)

## DA COMPILARE PER IL COLLAUDO

**DICHIARAZIONE DI CORRETTO MONTAGGIO:** la sottoscritta Ditta dichiara di aver montato in maniera corretta ed in conformità/alle prescrizioni sia del costruttore del veicolo che del costruttore del dispositivo stesso il seguente dispositivo di attacco meccanico:

tipo:.....

Il dispositivo di attacco sopra indicato è stato installato su autoveicolo

modello:.....

targa:.....

Data:.....

**TIMBRO e FIRMA**

**Si dichiara inoltre di aver informato l'utente del veicolo sull'USO e MANUTENZIONE del dispositivo stesso.**